

SG41HD Universal Grapple
OPERATION, MAINTENANCE AND
SPARE PARTS MANUAL

VALBY®

VALBY®



 **Northeast Implement Inc.**
Spencer, New York 14883
Tel: 607-589-6160
Fax: 607-589-4026
www.northeastimplement.com

**It is very important to read this entire owners/operators
manual before using this machine**

SG41HD Universal Grapple
OPERATION, MAINTENANCE AND
SPARE PARTS MANUAL



This Page Left Blank Intentionally

SG41HD Universal Grapple

OPERATION, MAINTENANCE AND SPARE PARTS MANUAL



TABLE OF CONTENTS

1. TO THE OWNER/OPERATOR.....	4
2. SAFETY INSTRUCTIONS.....	5
3. GENERAL SAFETY	6
4. CONNECTION & MOUNTING.....	8
4.1. Connecting to the Hydraulic System.....	8
4.2. Mounting.....	8
4.3. Protecting Hydraulic Hoses.....	8
5. OPERATION	9
5.1. Test Operation	9
5.2. Practicing.....	9
5.3. Operation Conditions.....	9
5.4. Operation Safety	9
5.5. Mounting Instructions	10
5.6. Lifting Loads	10
5.7. Service Instructions.....	10
5.8. Storage and Transport	10
6. ADDITIONAL SAFETY.....	11
6.1. Electrical Wires	11
6.2. Additional Cautions.....	11
7. TECHNICAL DATA.....	12
8. MAINTENANCE & LUBRICATION	13
9. EXCAVATOR GRAPPLE	14
10. DIVERTER VALVE	15
11. GRAPPLE	16
12. ROTATOR(45)	17
13. ROTATOR(Rigid)	20
14. WARRANTY.....	23
15. GRAPPLE RECOMMENDATIONS.....	25

SG41HD Universal Grapple

OPERATION, MAINTENANCE AND SPARE PARTS MANUAL



1: TO THE OWNER-OPERATOR

Thank you for purchasing a VALBY product

Before we begin this manual, the people at VALBY want you, the owner-operator, to know this piece of equipment can be very dangerous if safety procedures and warnings are ignored. Read this manual carefully page by page until you understand it completely. Failure to do so can and will result in personal injury and/or equipment damage.

All personnel including operators, maintenance crews, and bystanders, etc. should read this manual before start up.

This manual should be considered a permanent part of your equipment and should remain with the equipment if you sell it.

IMPORTER:

NORTHEAST IMPLEMENT Inc.
460 Halsey Valley Road
Spencer, NY 14883
U.S.A.

Phone: 607-589-6160
Fax: 607-589-4026
E-Mail: info@northeastimplment.com
Web: www.northeastimplement.com

Record Your Serial Number: SG41HD Grapple s/n: _____

R45 Rotator (Hanging) s/n: _____

RMR 06(Rigid) s/n: _____

Date of Purchase: ____/____/____

2: SAFETY INSTRUCTIONS

TERMS AND SYMBOLS USED IN INSTRUCTIONS



Safety is a combination of operator common sense and alertness at all times when the machine is being operated.



This message is used for general reminders of good safety practices or to direct attention to unsafe practices. The message will appear in your operators' manual and/or the sign will appear on the machine with a color combination of yellow and black



This Message denotes a specific potential hazard. The sign will be displayed on the machine in areas of potential hazard. The sign will have the color combination of yellow and black



This message denotes the most serious specific hazard. The sign will be displayed on the machine in areas of potential hazard.



Message labeled "Important" will appear in your operator's manual to provide specific instructions for performing adjustments, service, etc. If these instructions are not followed it could result in damage to the machine.

3: General Safety



Do not operate this machine until you have read the manual page by page and understand the manual. The owner of this machine is responsible for all operators and support personnel in the operation and safety precautions of this chipper. Proper training prior to operation of the chipper is obligatory.

- Study the manual and read all safety instructions carefully, including all instruction stickers on the machine.
- Before anyone uses the grapple, make sure that he/she also studies these instructions for use and all safety regulations
- The operator must be of age (not a minor) and in good health.
- The operator cannot be under the influence of alcohol, drugs or medicines.
- Stay alert! Do not operate the grapple when fatigued.
- In order not to endanger the safety of the operator, do not modify the machine.
- Use only original parts replacements. Remove all inappropriate components that don't belong to the machine.
- Install all protective shields in their proper place.
- Study the function of all controls.
- Place the attachment on the ground in such a position that it cannot move during maintenance, cleaning, adjustments, and installation of accessories or storage.
- Don't put the grapple into such uses, for which it is not designed.
- The danger zone is 80 feet; ensure that no one is inside the danger zone, take special note of children.
- Familiarize yourself with the controls and how to stop the machine in an emergency.
- Never leave the attachment hanging in the air.
- Do not wear loose or torn clothes. Keep hands, feet and clothing away from power driven parts.
- Never go under the attachment or the load. Always operate the grapple from the cab of the machine.
- Check the tightness of all nuts and bolts after the first service hour. Also check the tightness at least once a month. They should be fastened in place, and in good working condition.
- Before lubricating the machine, shut down the engine and stop the machine.
- Observe possible leakage of hydraulic oil during the use of the machine. Repair leaks immediately to prevent contamination of nature.
- Pressurized oil can be hazardous. Pressurized oil jet can penetrate skin and cause serious injuries or death.

SG41HD Universal Grapple

OPERATION, MAINTENANCE AND SPARE PARTS MANUAL



- Wear protective gloves and other protective clothing to prevent exposures.
- In case you install a new additional valve system, you have to take into consideration that pressurized hydraulic hoses cannot be in the cabin area without protection.
- The valve controls must be installed in the cabin of the equipment.
- The attachment is designed for short distance transfer of timber on a landing. Carrying a load is not allowed during highway driving.
- Failure to heed the warnings printed on the grapple or in the operator's manual may result in serious injury or death!

4: CONNECTION & MOUNTING

4.1 CONNECTING TO THE HYDRAULIC SYSTEM

The circuit must be cleaned carefully. Oil should be circulated throughout the hydraulic system when the hydraulic system is up to operating temperature. This will lead the dirt particles to the filter. The loader must have a relief valve that restricts the pressure coming to the rotator to 3000 PSI. The connection to the hydraulic system requires two double acting valves. The housing of the rotor is marked for hook up as follows:

- G<> Opening of the grapple
- G>< Closing of the grapple
- R< Rotator turning to the direction of the pointer
- R> Rotator turning to the direction of the pointer



As the grapples often have a maximum working pressure of 2900 lbs., one can put a pressure relief valve if needed to the

circuit which is closing the grapple. When operating the grapple, don't leave the grapple open or closed in the machines extreme positions. This leaves pressure inside the grapple.

4.2 Mounting

Do not start the oil flow before operating valve is connected to the hydraulics.

The recommended way is to connect the pressure hose to a single acting hydraulic

output, and the return hose via filter to tank.

When the crane is connected to a double acting hydraulic connection, the pressure and return hoses are coupled to their own connections. Note that the machines' lever for double action valve directs the pressure correctly to cranes operating valves pressure connection.

Make sure the quick couplers lock when they are connected.

Place the control box at a convenient location in the cab.

Hook up the wires that go into the control box into a 12 volt DC battery so that the red wire goes to the positive terminal, and the black wire to the negative terminal.



The maximum pressure is 2900 PSI. If your machines' relief valve is set to higher pressures, you must add a second relief valve to protect the grapple.



4.3 Protecting Hydraulic Hoses

Hydraulic hoses must be placed and protected so that they are not exposed to rubbing, torque or mangling.

If pressure hoses must be led through operator's cabin, they must be protected, so that in case of breakage, nobody is endangered by oil spray.

5: OPERATION

5.1 Test Operation



Test out the grapple when the machine is running at idling speed so the movements of the grapple will be slow.

To bleed air from the system, cautiously operate the different movements one by one to their extreme positions, until the movements are smooth. The solenoid valve restricts you to use one function at a time. You can open or close the jaws, or run the rotator, but not simultaneously.

After test operation, check hoses and connections.

Fill up the hydraulic oil tank.

5.2 Practicing



Read and understand the operation and safety instructions before using the grapple.

Learn to control every operation of the grapple with an empty grapple. It is beneficial to adjust the pumps output as low as possible when you are practicing. This makes avoiding sudden movements easier. After you are accustomed to the grapples movements, choose an engine speed so that operation is efficient, but you still have the movements well under your control.

5.3 OPERATION CONDITIONS



This rotator is intended to be used on hydraulic loaders such as log loaders. The axle of the rotator is fastened to a grapple.

Using the rotator, one can turn the load horizontally. The oil for opening and closing the jaws of the grapple is piped thru the axle of the rotator. The maximum lifting capacity of the grapple should not be bigger than the maximum lifting capacity of the rotator. When using the rotator, one should ensure that the oil flows normally. The working temperature of the grapple is between -10F degrees to 120F degrees.

5.4 OPERATION SAFETY



- Ensure that the highest load capacity of the rotator is not exceeded.
- Ensure that the hydraulics have reached operational temperatures.
- Check the speed and the direction of the motions, and the function of the controls.
- Lift up the load before using the rotator. Do not drag the load.
- Closely observe the load when lifting it, the rotator does not have a brake and the load might turn due to wind or an unbalanced load.
- To stop the motion of the load, one must take corrective action from the valve.

- Ensure that the hydraulic hoses do not come into contact with obstacles. The breakage of a hose or a fitting might cause the dropping of the load or the continued turning of the rotator.

5.5 MOUNTING INSTRUCTIONS

The rotator is hooked thru a hanger to the lifting boom. The rotator must always be able to hang freely in a vertical position. The swinging motion of the rotator should be restricted, and the hydraulic hoses should be protected so that there is no risk for damage

5.6 LIFTING LOADS



Use the loader and the rotator with care according to the safety instructions included with the loader.

Avoid stressing the rotator axle sideways. For example, dragging a load before it is lifted off the ground is prohibited. Breakage of a hydraulic hose or a fitting might cause the load to drop or the rotation to continue. Damage to a hose might cause a high pressured oil spray.

5.7 SERVICE INSTRUCTIONS

The rotator must be serviced if the rotation is becoming uneven and stops temporarily. The pin which fastens the rotator to the boom must be greased once a week. The rotator hookup to the boom and the condition of the hoses must be checked once a week for breakage. Possible oil leaks or damage must be repaired immediately. If the pressure of

the grapple has diminished, or if it is opening by itself, check the seals that lead the oil through the rotator shaft. The torque of the bolts that tie the rotator together must be checked once a year. Repairing the rotator by welding is forbidden. Replacement of seals and other components must be done by a qualified technician.

5.8 STORAGE AND TRANSPORT

The hook ups to the rotator have to be kept closed or protected with plugs if the rotator is dismantled from the loader. The rotator should be protected from moisture and extreme temperature changes.

6: ADDITIONAL SAFETY

6.1 Electrical Wires

If an Electric Wire is Touching Your Machine



When working close to live electric wires, comply with the 80 ft. danger zone.

If the machine comes into contact with high voltage electric wires comply with following instructions:

If you are outside the machine do not touch any part of the machine. Do not attempt to get into the machine. Keep everybody out from the machines vicinity.

If you are inside the machine get out of it by jumping. Avoid touching any conducting parts. Do not make yourself a conductor through which electricity may flow. Get away from the machine by jumping so that no part of your body is in contact with the machine when you hit the ground. The electric field conducted by the ground can cause fatal voltage.

You are safe at about 70 ft. from the wire. Call for help.

6.2 ADDITIONAL CAUTIONS



The operator must observe the load during the lift. The rotator does not have a brake. If the load moves, for example, due to wind, or if the load is not in balance, the movement of the load has to be stopped by corrective action of the operator.

Warnings:

The warnings, cautions and instructions discussed in this manual cannot cover all possibilities conditions and situations that may occur. It must be understood by the operator that common sense and caution are factors which cannot be built into this product, but must be supplied by the operator.

SG41HD Universal Grapple

OPERATION, MAINTENANCE AND SPARE PARTS MANUAL



7: TECHNICAL DATA

Grapple SG41HD	
Weight	276 lbs
Lifting Capacity	8,819 lbs
Gripping Force	3,035 ft/lbs
Gripping Area	2.4 sq. ft
Maximum Pressure	2,901 psi
Recommended Flow	11 gpm
Recommended Excavator	Up to 5 ton
Rotator R45(Hanging Application)	
Rotation	Unlimited
Weight	53 lbs
Lifting Capacity	9,921 lbs
Maximum Pressure	3,625 psi
Flow Rate	3 gpm
Displacement	17 cubic inches
Torque	516 ft/lbs
Rotator RMR06 (Rigid Application)	
Rotation	Unlimited
Weight	135, lbs
Lifting Capacity	15,432 lbs
Maximum Pressure	4,640 psi
Flow Rate	6 gpm
Displacement	24 cubic inches
Torque	2065 ft/lbs

VALBY SG41HD Universal Grapple	Pos.	Measure
	A	41"
	B	20"
	C	25"
	D	4"
	E	14"

SG41HD Universal Grapple

OPERATION, MAINTENANCE AND SPARE PARTS MANUAL



8: MAINTENANCE & LUBRICATION

	First 8 Hours	Every 20 Hours	Monthly	Procedure
Grapple				
Bolts/Nuts	X		X	Check for Tightness
Joints		X		Grease
Rotator				
Flange	X		X	Check for Tightness
All Hyd. Fittings	X		X	Check for Tightness/Leaks

SG41HD Universal Grapple

OPERATION, MAINTENANCE AND SPARE PARTS MANUAL



9: EXECAVATOR GRAPPLE



Spare Parts List for Excavator Grapple

Part	Order #	Description	Qty
1	SG41HD	VALBY 41" HD Grapple (See Enclosed Parts Breakdown)	1
2	511502	Long Grapple Hose	1
3	141150	Flange(R45 Only)	1
4	R45	Intermercato Rotator (See Enclosed Parts Breakdown)	1
	RMR06	Intermercato Rotator (See Enclosed Parts Breakdown)	
5	145840	Hanger	1
6	Hanger on Plate	Model Specific	1
7	75012005	Diverter Valve to Rotator Hoses	4
	75012008	Lead Hoses when sold W/out Diverter Valve	4
8	511502	Short Grapple Hose	1

SG41HD Universal Grapple

OPERATION, MAINTENANCE AND SPARE PARTS MANUAL



10: DIVERTER VALVE (Optional)



Spare Parts List for Optional Diverter Valve's

Part	Order #	Description	Qty
1	75002004	Rexroth Diverter Valve Complete (Square Coil)	1
2	75107500	DIN Connector	1
3	75107600	Plastic Nut	1
4	75104000	12V Coil Square	1
	75104500	24V Coil Square	

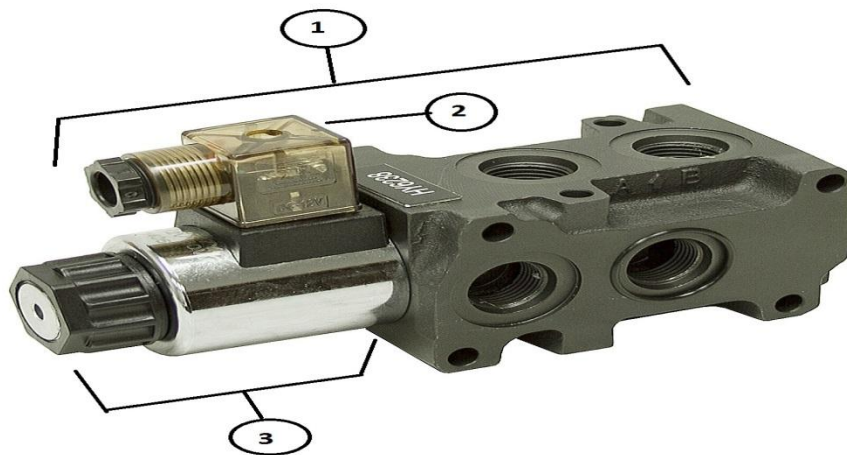

Part	Order#	Description	Qty
1	75002003	Badestnost Diverter Valve Complete (Round Coil)	1
2	75107500	DIN Connector	1
3	75104100	12V Coil Round	1

SG41HD Universal Grapple

OPERATION, MAINTENANCE AND
SPARE PARTS MANUAL



11: GRAPPLE

VALBY SG41HD Universal Grapple

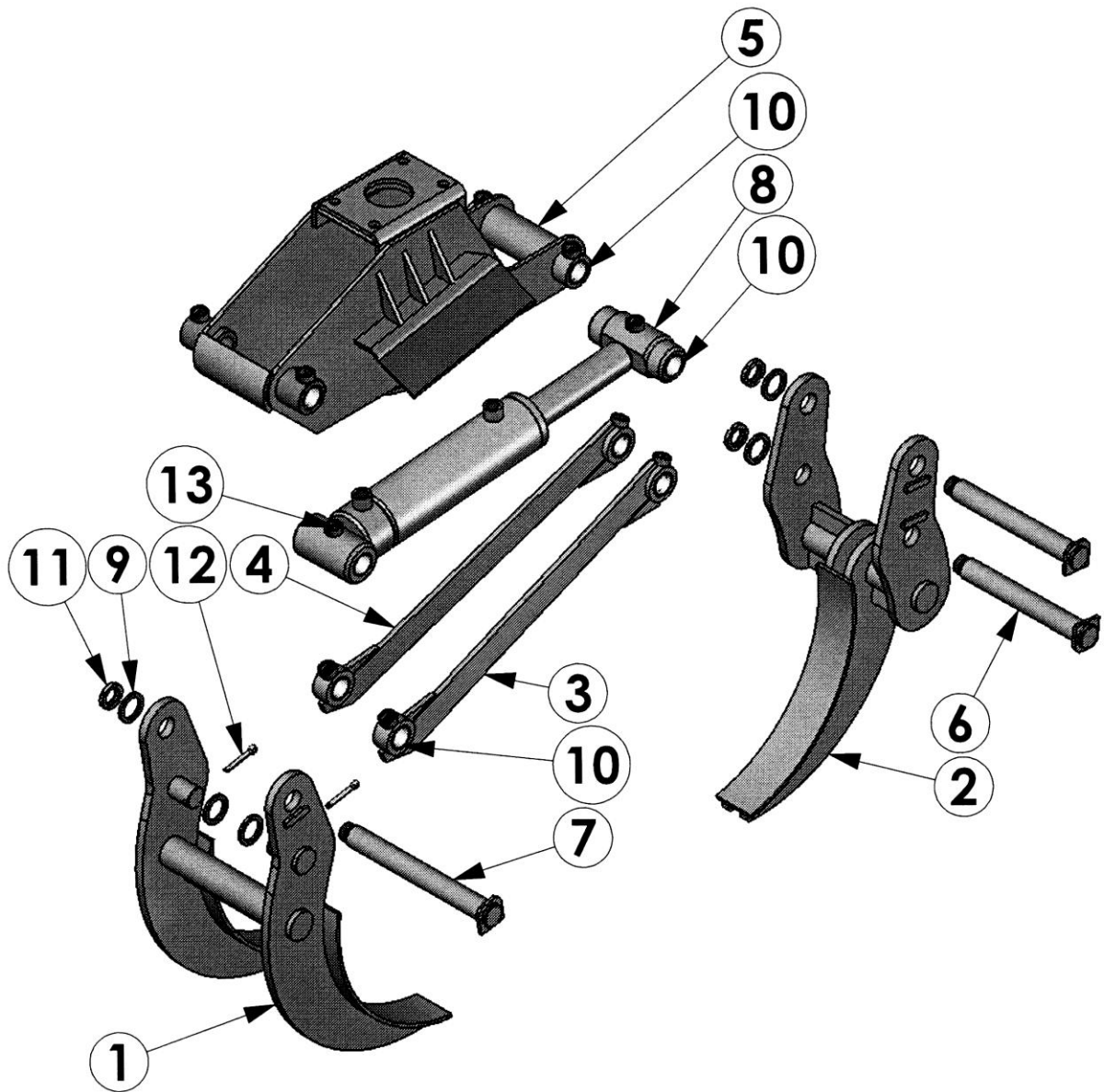

SG41HD Universal Grapple

OPERATION, MAINTENANCE AND SPARE PARTS MANUAL



Parts List

Pos	Part#	Name	Description	Qty
1	272730	Outer claw	Griffe extérieur	1
2	271730	Inner claw	Griffe intérieur	1
3	274301	Guide bar	Barre directrice	1
4	274302	Guide bar	Barre directrice	1
5	273331	Body	Corps	1
6	276330	Shaft	Axe	2
7	276332	Shaft	Axe	1
8	286302	Cylinder	Cylindre	1
9	818270	Washer	Rondelle	5
10	821308	Bushing 3530	Bague 3530	12
11	852165	Castle nut M30	Ecrou de blocage	3
12	861500	Split pin	Goupille fendue	2
13	548100	Grease nipple	Graisser	9
	786302	Seal kit	Kit de joints	1

SG41HD Universal Grapple

OPERATION, MAINTENANCE AND SPARE PARTS MANUAL



12: ROTATOR(R45)

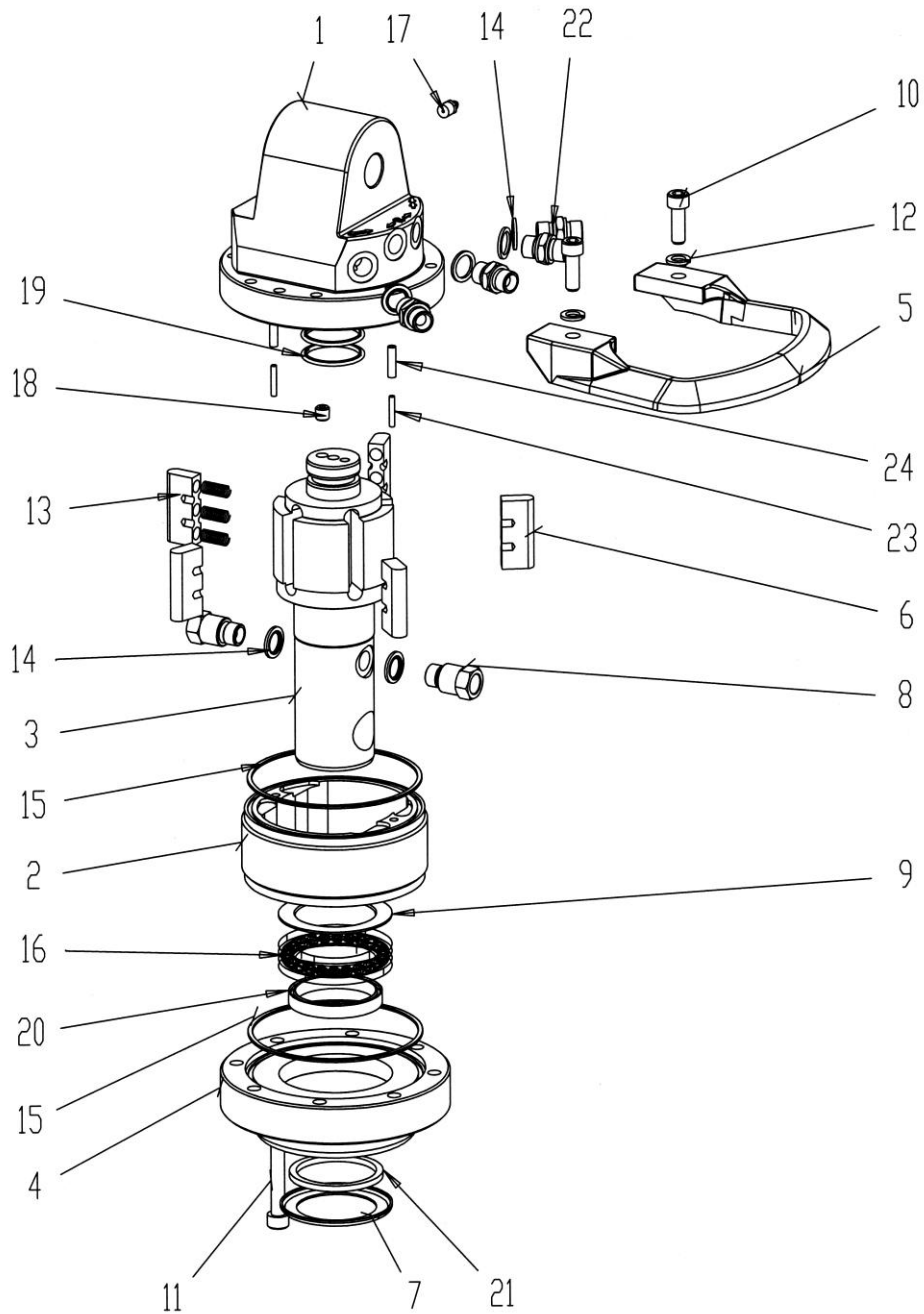

SG41HD Universal Grapple

OPERATION, MAINTENANCE AND SPARE PARTS MANUAL



Parts List

Pos	Art.	Description	Qty
1	186312	Top cover	1
2	184312	Stator frame	1
3	183312	Rotor shaft	1
4	185312	Bottom cover	1
5	182312	Nipple guard	1
6	837312	Vane	5
7	817312	Cover plate	1
8	544210	Fitting shaft	2
9	811312	Shim	1
10	842150	Screw	2
11	842400	Screw	8
12	814310	Spring washer	2
13	833100	Spring	15

14	815150	Washer	6
16	831200	Thrust ball bearing	1
17	548060	Grease nipple	1
18	567302	Tapered plug	1
22	541006	Fitting	4
23	835124	Pin	2
24	835126	Pin	2
	781310	Seal kit	1
15	747600	O-ring	2
19	734100	Piston rod seal	2
20	733500	Piston rod seal	1
21	757150	V-ring	1

SG41HD Universal Grapple

OPERATION, MAINTENANCE AND SPARE PARTS MANUAL



13: ROTATOR(RMR03)

RMR 3

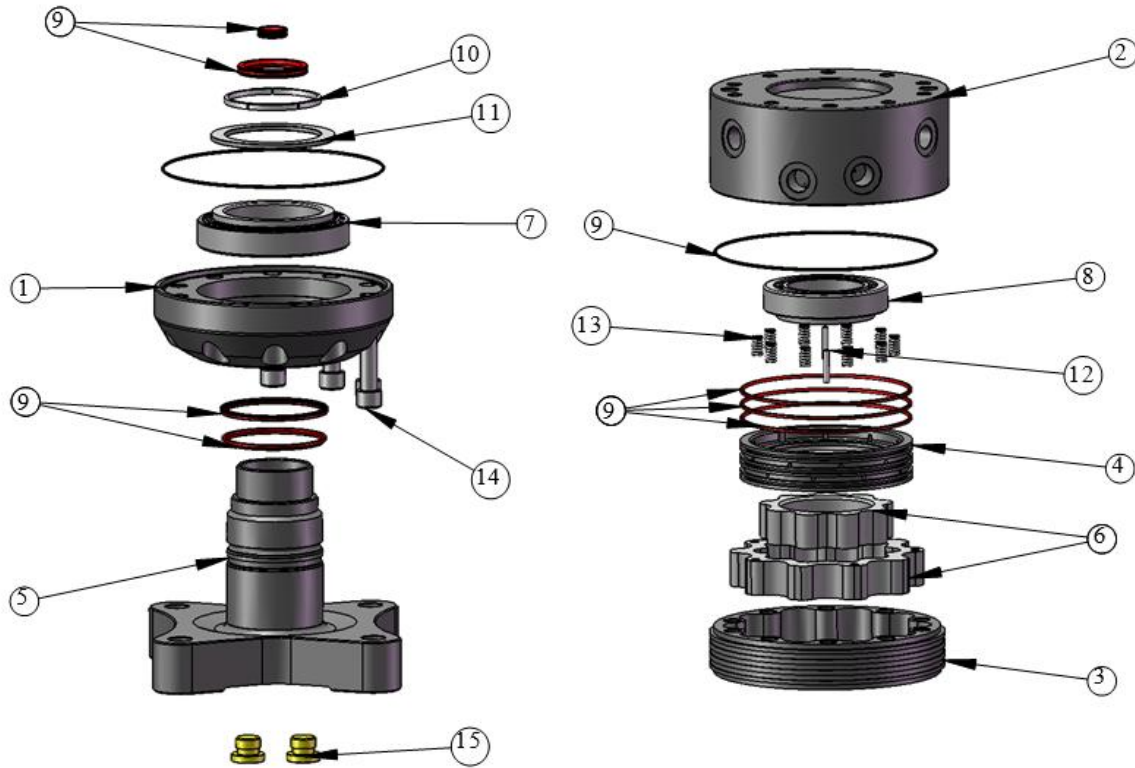

Part #	Nr	Description	Qty.
101000	1	Motor Housing	1
102500	2	Motor Head	1
103000	3	Rotor Housing	1
104000	4	Distributor Plate	1
105000	5	Flange Shaft	1
107000	6	Rotor	1
110100	7	Taper Roller Bearing	1
110150	8	Taper Roller Bearing	1
115000	9	Seal Kit	1
110800	10	Safety Ring	1
110810	11	Supporting Ring	1
110500	12	Cylindrical Pin	2
110600	13	Pressure Spring	10
111100	14	Cylinder Bolt	10
111500	15	Screw, Tapered Grub/VSTI	2

SG41HD Universal Grapple

OPERATION, MAINTENANCE AND SPARE PARTS MANUAL



13b: ROTATOR(RMR06)

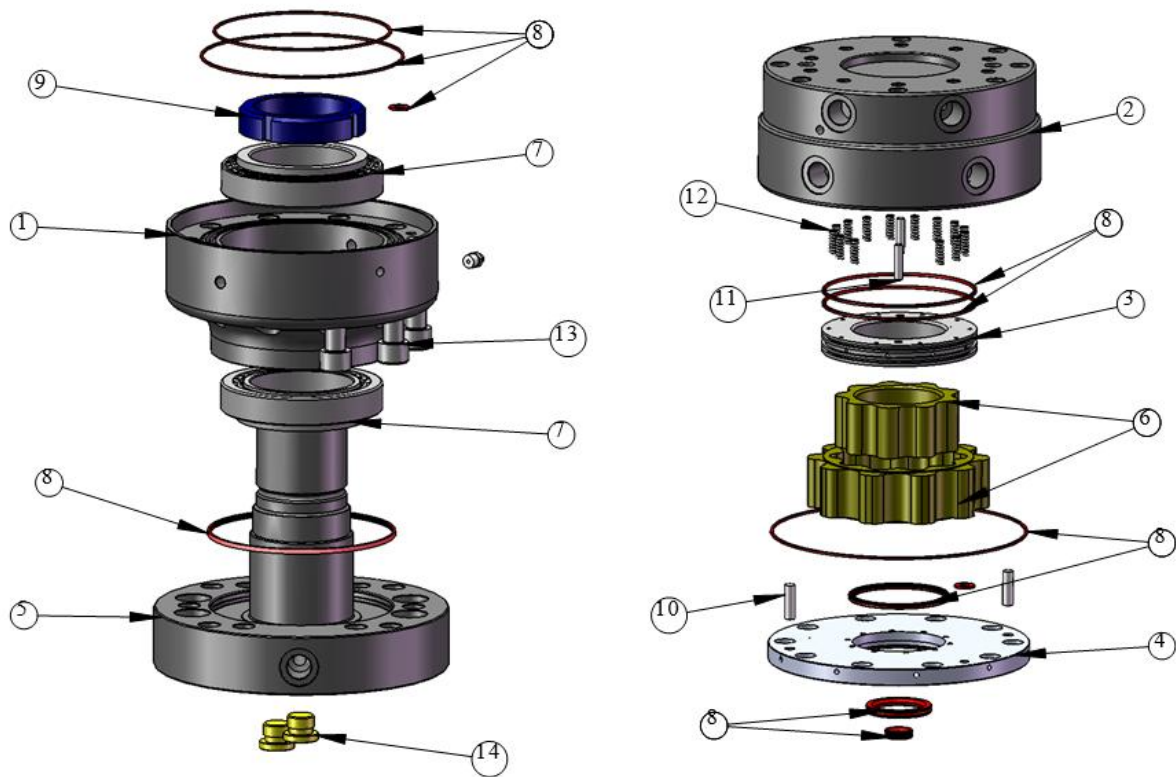

Part #	Nr	Description	Qty.
401500	1	Motor Housing	1
402500	2	Motor Head	1
403500	3	Valve Plate	1
404500	4	Distributor Plate	1
405500	5	Flange Shaft	1
407000	6	Rotor Housig	1
410100	7	Taper Roller Bearing	2
415000	8	Seal Kit	1
410300	9	Shaft Nut	1
410500	10	Cylindrical Pin	2
410520	11	Cylindrical Pin	2
410600	12	Pressure Spring	15
411170	13	Cylinder Bolt	10
411500	14	Screw, Tapered Grub/VSTI	2

SG41HD Universal Grapple
OPERATION, MAINTENANCE AND
SPARE PARTS MANUAL



This Page Left Blank Intentionally

SG41HD Universal Grapple

OPERATION, MAINTENANCE AND SPARE PARTS MANUAL



Take
Form
Manufacturer
Here

Limited Warranty

VALBY warrants the product to be free from defects in materials and workmanship for twelve (12) months from date of purchase, or one month from in-service, whichever is longer. For seals, the warranty is limited to six (6) months. The warranty covers parts replacement only. The free replacement of parts is exclusive. The manufacturer is not liable for any incidental or consequential damages. No labor costs cost are included, no freight costs are included in replacements. This warranty does not cover defects resulting from:

- misuse of product
- inadequate maintenance
- modifications of the product

The warranty is effective only, if the lower portion of this card is completed and returned to the importer within 14 days of receipt of the product.

IMPORTANT: Do not operate your equipment without reading the operators manual! If the operators' manual was lost, a new manual can be obtained from the importer (write address below or call 607-589-6160).

Date of Delivery: ____/____/____

Customer: _____

Address: _____

City: _____

State, Zip _____, _____

Telephone# (____) _____ - _____

Product: SG41HD Universal Grapple

Serial# _____

Purchased From: _____

Importer:

Northeast Implement Inc.

460 Halsey Valley Road

Spencer, NY 14883

USA

Phone: (607) 589-6160

Fax: (607) 589-4026

Email info@northeastimplement.com

Website: www.northeastimplement.com

****Please remove this page and mail to address above for warranty registration****

On-line at www.northeastimplement.com, under "Products" tab, click "Product Registration"



General Warranty Terms

Intermercato Rotators

Intermercato warrants that the products are free from defects in materials and workmanship. The product warranty is strictly limited to defects in materials and manufacturing and does not include damage caused by incorrect mounting, misuse, abuse or overloading.

The warranty covers repair or replacement of defective parts. The products are not to be returned without prior notice and Intermercato's approval.

The product warranty is twelve (12) months from sales date, for seals, the warranty is limited to six (6) months.

Travel costs and costs of mounting are not covered by this warranty.

The warranty is not valid if the products have been repaired, altered or dismantled, even partly.

The warranty does not cover secondary damage.

The warranty is effective only, if the lower portion of this card is completed and returned to the importer within 14 days of receipt of the product.

IMPORTANT: Do not operate your equipment without reading the operators manual! If the operators' manual was lost, a new manual can be obtained from the importer (write address below or call 607-589-6160).

Date of Delivery: ____/____/____

Customer: _____

Address: _____

City: _____

State, Zip _____, _____

Telephone# (____)____-_____

Product: R45 Rotator, RMR Rotator

Serial# _____

Purchased From: _____

Importer:

Northeast Implement Inc.

460 Halsey Valley Road

Spencer, NY 14883

USA

Phone: (607) 589-6160

Fax: (607) 589-4026

Email info@northeastimplement.com

Website: www.northeastimplement.com

****Please remove this page and mail to address above for warranty registration****

On-line at www.northeastimplement.com, under "Products" tab, click "Product Registration"

SG41HD Universal Grapple

OPERATION, MAINTENANCE AND SPARE PARTS MANUAL



15: GRAPPLE RECOMMENDATIONS

PLEASE READ THE FOLLOWING TO AVOID YOUR WARRANTY BEING VIOLATED

The following are the current manufacturer recommendations for grapples and rotators based on applications and excavator size. Any uses of the grapples and rotators that vary from these recommendations may void any warranty claim you may have.

Standard Log Grapples

	Cranes ton meter max	Rotator	Excavator size cardanic mount	Rotator	Excavator size rigid mounting	Rotator
GR28	2	IVR 3	2	IVR 3	0	
GR36	2	IVR 3	2	IVR 3	0	
GR50	3	4.59/IVR4FG	3	4.59/IVR4FG	0	
GR50 Pro	4	RX 55F6	4	RX 55F6	0	
GR55	5	RX 55F6	5	RX 55F6	0	
GR60	7	RX60F	7	RX60F	0	
GR75	15	GV12	15	GV12	0	
GR100	20	GV12S	20	GV12S	0	

Heavy Duty Log Grapples

GR50HD	4	IVR 4.59/IVR4FG	4	IVR 4.59/IVR4FG	3	RMR03
GR55HD	5	RX 55F6	6	RX 55F6	4	RMR06
GR60HD	15	RX 120.2/RX 120S	15	RX 120.2/RX 120S	10	RMR06
GR75HD	20	RX 120S	20	RX 120S	14	RMR08
GR100HD	30	RX 120S	30	RX 120S	20	RMR12

Universal/Sorting Grapples

SG36HD	3	IVR 3	3		2	RMR03
SG52HD	4	IVR 4.59	4		3	RMR03
SG48HD	8	RX 55F6	8		7	RMR06
TG 12 UG/7	1.5	IVR 3	4		2	RMR03
TG 22 UG/9	12	RX 60F	10		7	RMR06
TG 28 UG/11	15	GV12	15		10	RMR08
GX 28-50	20	GV12	20		14	RMR12
TG 36 UG/13	20	GV12S	20		14	RMR12
TG 55 UG/11	30	GV12S	30		20	0

SG41HD Universal Grapple

OPERATION, MAINTENANCE AND SPARE PARTS MANUAL



Demolition Grapples

	Cranes ton meter max	Rotator	Excavator size cardanic mount	Rotator	Excavator size rigid mounting	Rotator
TG 20 DG	0				10	RMR16
TG 20 DGW	0				12	RMR16
TG 25 DG	0				17	RMR20
TG 30 DG	0				22	RMR20
TG 35 DG	0				25	RMR20

Clamshell Buckets

TGS 12-40	0.5	IVR 3				
TGS 12-50	0.5	IVR 3				
TCB 500	10	IVR 4.59/IVR 4FS	10	IVR 4.59/IVR 4FS	7	RMR06
TCB 650	12	IVR 4.59/IVR 4FS	10	IVR 4.59/IVR 4FS	7	RMR06
TCB 800	15	RX55.69/RX55F	10	RX55.69/RX55F	7	RMR06
TCB 1000	20	RX55.69/RX55F	10	RX55.69/RX55F	7	RMR08
TCB HD 1250	25	GV12	15	GV12	10	RMR12
TCB HD 1500	25	GV12	15	GV12	10	RMR16
Superchip	25	GV12S	15	GV12S	10	RMR20



NOTES

SG41HD Universal Grapple
OPERATION, MAINTENANCE AND
SPARE PARTS MANUAL



Thank you for your purchase...

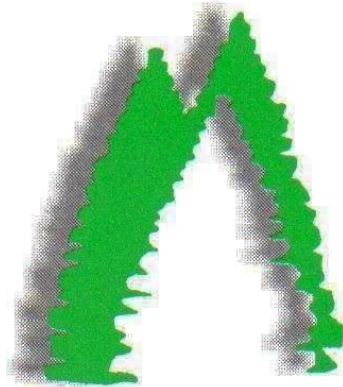

Northeast Implement Inc.

Spencer, NY 14883

Tel: 607-589-6160

Fax: 607-589-4026

www.northeastimplement.com

